

Dimension Table for: 0103P0001				
ISO 1127	E	C4	C2	D
DN8*	34,0	10,5	27,5	36,2
DN10*	34,0	14,2	27,5	36,2
DN15*	34,0	18,2	27,5	36,2
DN8 *	50,5	10,5	43,5	52,7
DN10 *	50,5	14,2	43,5	52,7
DN15	50,5	18,4	43,5	52,7
DN20	50,5	23,9	43,5	52,7
DN25	50,5	29,9	43,5	52,7
DN32*	50,5	38,6	43,5	52,7
DN32	64,0	38,6	56,5	66,2
DN40	64,0	44,5	56,5	66,2
DN50	77,5	56,6	70,5	79,7
DN65	91,0	72,3	83,5	93,2
DN80	106,0	85,1	97,0	108,2
DN100	130,0	110,5	122,0	132,2
DN125	155,0	134,7	146,0	157,2
DN150	183,0	163,4	174,0	185,2
DN200	233,5	214,3	225,0	235,7
DN250*	286,0	268,0	276,0	288,2
DN300*	338,0	318,9	328,0	340,2

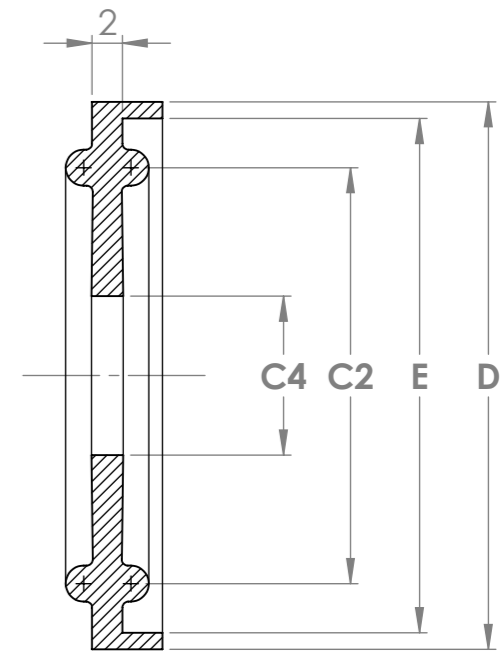
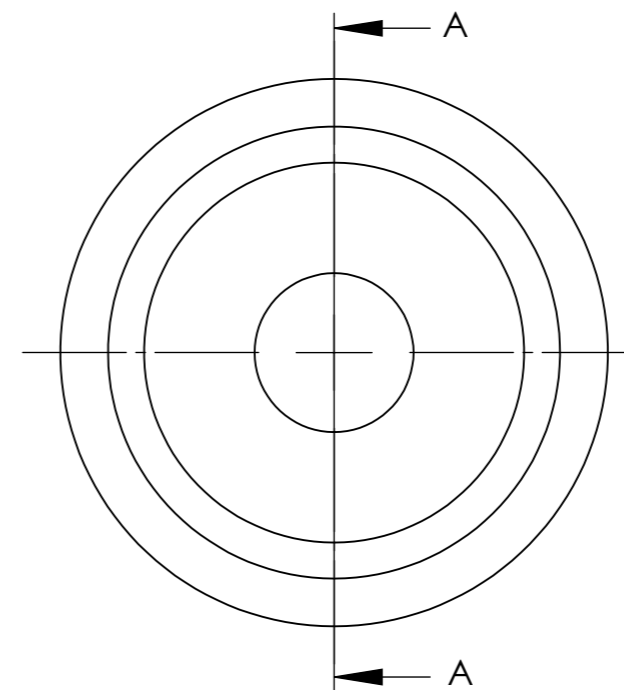
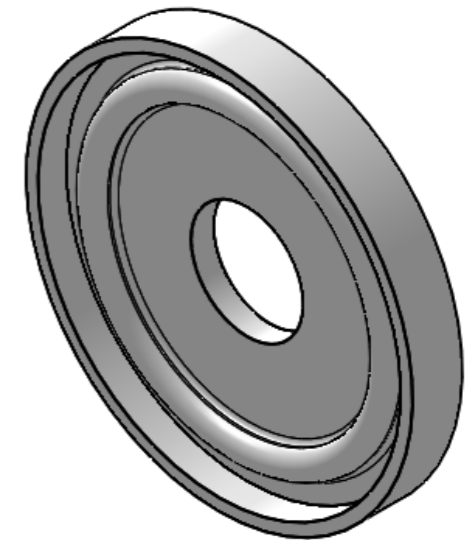
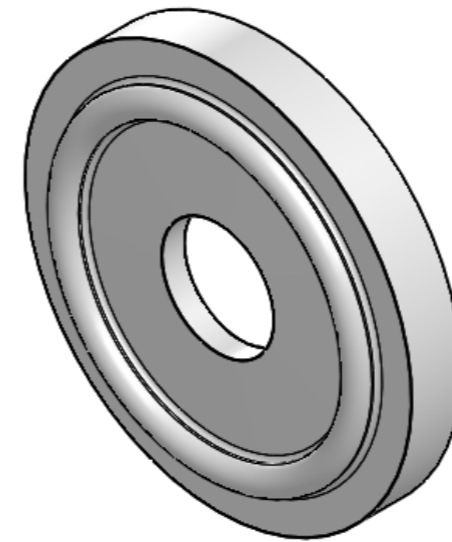

SECTION A-A

**UP Ultrapharma**

info@ultrapharma.com 1967 DB Heemskerk T: +31-(0)251-207050  
www.ultrapharma.com The Netherlands F: +31-(0)251-207055

CONFIGURATION see table	DESCRIPTION: ISO 1127 ELASTOMER FLANGED	3RD ANGLE PROJECTION 	UNITS: mm	SCALE: 2:1	SHEETSIZE A3
The information contained in this drawing is the sole property of Ultrapharma BV. Any reproduction in part or as a whole without written permission of Ultrapharma BV is prohibited.					