

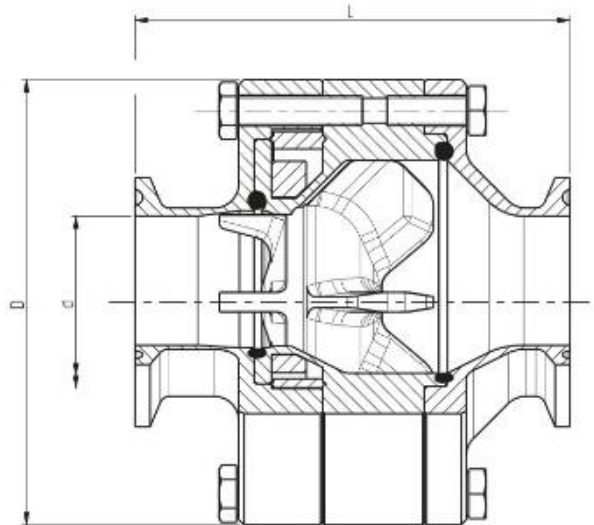

# EDF-3A

## TECHNICAL DATA

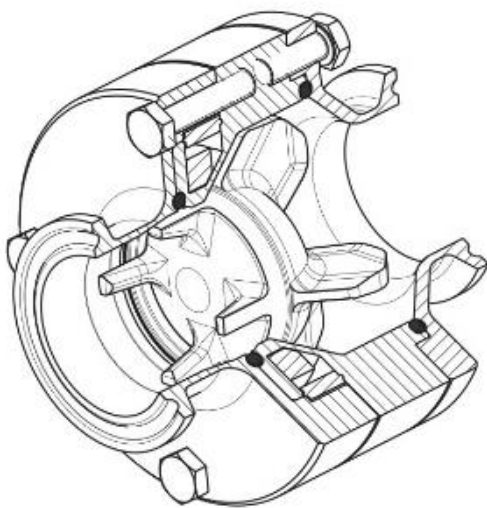

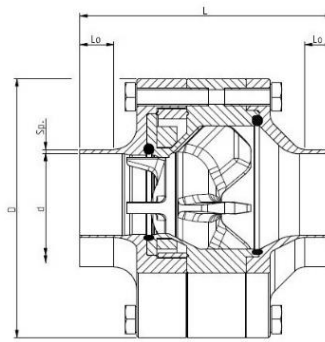
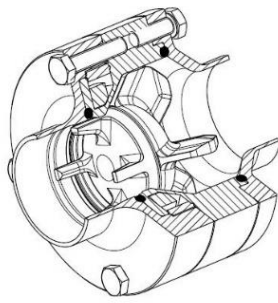

DIN 11850 (DIN 11866 Reihe A) > R

Dimension	L (mm)	D (mm)	d (mm)	Sp (mm)	Lo (mm)	Weight (kg)
DN6	51	41	8	1	6	0,3
DN8	51	41	10	1	6	0,3
DN10	51	41	13	1,5	6	0,3
DN15	60	54	19	1,5	6	0,6
DN20	72	72	23	1,5	5	0,8
DN25	72	72	29	1,5	5	1
DN32	88	90	35	1,5	5	1,8
DN40	88	90	41	1,5	10	1,8
DN50	98	104	53	1,5	10	2,7
DN65	115	130	70	2	10	5,3
DN80	140	153	85	2	8	9
DN100	150	174	105	2,5	10	12
DN125	160	210	129	2	9	18,5
DN150	165	245	155	2	9	25
DN200	173	295	204	2	9	33,5

ASME BPE (DIN 11866 Reihe C) > T

Dimension	L (mm)	D (mm)	d (mm)	Sp (mm)	Lo (mm)	Weight (kg)
½"	51	41	12,7	1,65	7	0,3
¾"	60	54	19,05	1,65	6	0,6
1"	72	72	25,4	1,65	9	1,3
1-1/2"	88	90	38,1	1,65	10	1,8
2"	98	104	50,8	1,65	10	2,7
2-1/2"	115,4	130	63,5	1,65	5	5,2
3"	140	153	76,2	1,65	8	9
4"	150	174	101,6	2,11	9	11,7
6"	179,5	245	152,4	2,77	10	25

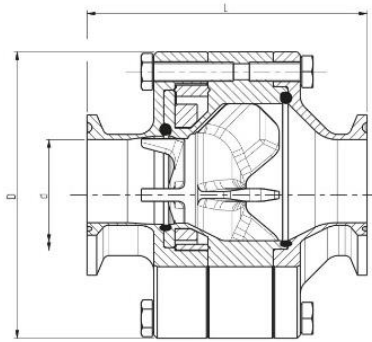
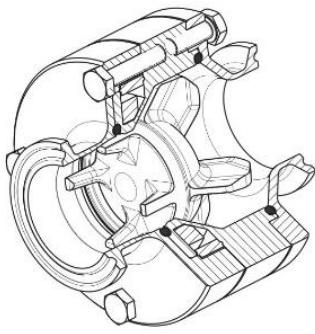

ASME BPE > C

Dimension	L (mm)	D (mm)	d (mm)	Weight (kg)
½"	61	41	9,4	0,3
¾"	70	54	15,7	0,6
1"	77	72	22,1	1,2
1-1/2"	88	90	34,8	1,8
2"	98	104	47,5	3
2-1/2"	117,4	130	60,2	5,2
3"	145	153	72,9	9,5
4"	155	174	97,4	12,2
6"	183,5	245	146,86	25