



Ultrapharma<sub>by</sub>

SNAP-ON™

---

**PROPERTY OF**  
ULTRAPHARMA B.V.

**LAST UPDATED**  
OCTOBER 2021

---

# SNAP-ON™ EXPLAINED

The Snap-On™ gasket has been developed for several reasons.

- Resolving Over-Compression
- Fixing Misalignments in pipework
- Colour identification
- Dimension Identification



## OVER COMPRESSION

This is a common problem with elastomeric gaskets. The typical shape of the Tri-Clamp and the ferrules are designed to match. Both components have a built-in 20° angled surface so when the wing nut is closed. The clamp slides over the surface of the ferrule compressing the gasket in an axial direction. In theory, until the gasket is flush with the internal diameter of the pipe illustrated in figure 1. In the real world, it is impossible to know when the gasket is flush with the ID, simply because we can't look inside the pipe-work.

Fig. 1

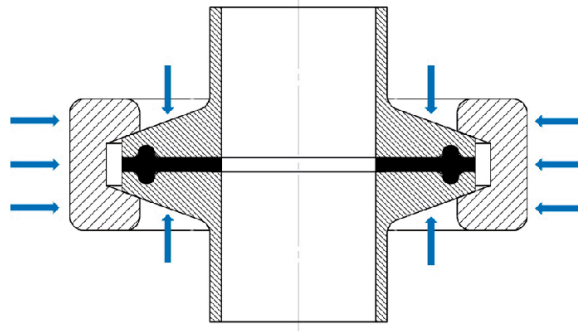

As the human mind seeks security and therefore we apply a couple more turns to the wing-nut, this pushes the gasket over the edge creating a situation as illustrated in figure 2. The gasket material is now inside the flow pattern.

Fig. 2

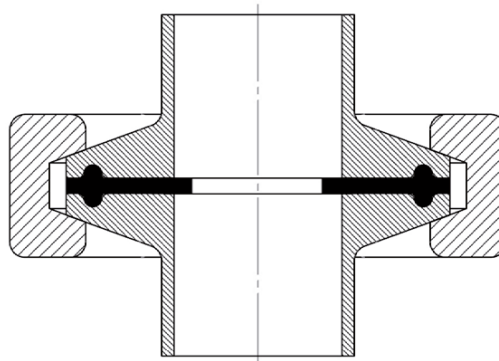

## MISALIGNMENT

Another common problem is a misalignment in pipe-work. During maintenance, things might change. For example, the position of a valve is slightly different from before and has now shifted a little. Although welders are spending lots of time on alignment the pipe work changes when exposed to heat, creating stress and causing the shifting. In this situation when we need to install a new gasket, we use the clamp to bring the two ferrules together and seal the connection. In figure 3 we illustrate this scenario, in figure 4 the devastating result.

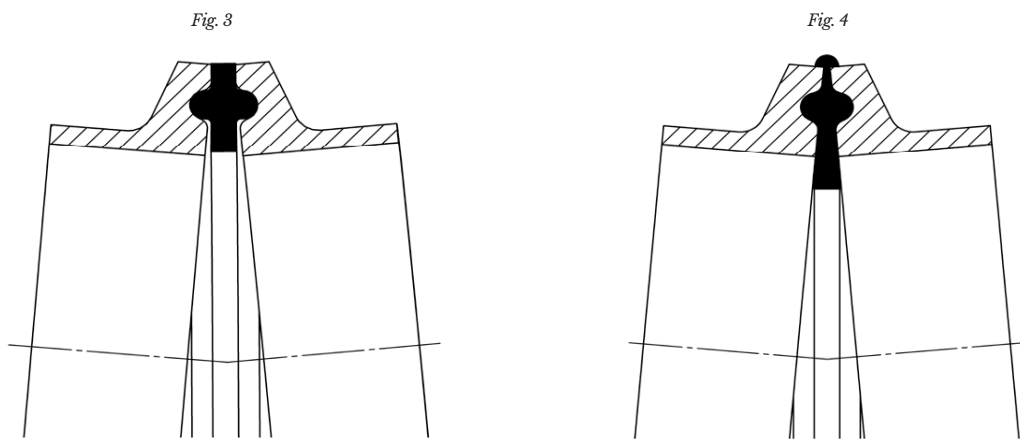

## COLOUR IDENTIFICATION

Fully applying colour to an elastomer is an interesting thought. It allows distinguishing between different production runs, to eliminate cross-contamination from the gaskets. Blue gaskets for product A, green gaskets for product B. It can be very helpful when exchanging all gaskets during maintenance, all grey gaskets need to be taken out and replaced with green gaskets. The difficulty with the coloured elastomer is the validation of the raw material when biological reactivity is important. Each colour needs to be validated first. This is a very expensive exercise.



## DIMENSIONAL IDENTIFICATION

A coloured gasket can be used to designate a certain dimension. The flange diameter of a 1" ferrule and a 1.5" ferrule are the same, both 50,5 mm. These two gaskets are differentiated only by the internal diameter, as illustrated by the two gaskets below, yellow is 1" and red is 1,5". If these were both in black EPDM and placed inside the pipework, you can't see from the outside if the correct gasket is between the ferrules. By using the yellow and red gaskets you can see from the outside if they are installed in the correct ferrules. See photos below. Same as with colour identification the individual compound validation might be a financial challenge.



## SNAP-ON™ ADVANTAGES

- One compound, many colours

The Snap-On™ gasket has a high-performance plastic ring on the outside. This ring can be made in virtually every colour. The first advantage is that we can use one validated compound, in combination with unlimited plastic coloured rings on the outside. From a validation point of view, a good situation.

- Easy to snap on and off

The three gaps allow for easy disassembly, the three lips facilitate the snapping-on to the ferrule.

- Preventing over-compression

Over-compression of elastomeric gaskets is one of the biggest problems in our industry. On page two of this brochure, we have explained the problem. The Snap-On™ gasket has this plastic ring on the outside that is just a little thinner than the actual elastomer gasket itself. Place the gasket over one ferrule by snapping it on. Place the other ferrule on top of the gasket and put a clamp around the fittings. When you turn the wing-nut, you will first compress the rubber material until the ferrule hits the plastic ring. Soon you will notice that you are not able to turn the wing-nut any further. The plastic ring creates a full stop.



It is impossible to further (over-) compress the gasket. Even in a situation where there is pipe misalignment, as described on page 3, the plastic ring will prevent that the gasket is crushed on one side (figure 5). The plastic ring will absorb the mechanical force that is needed to bring the two ferrules together. Even bringing the two ferrules together with an excessive amount of force will not destroy the elastomeric gasket (figure 6). The gasket is now flush with the internal diameter of the ferrule.

Fig. 5

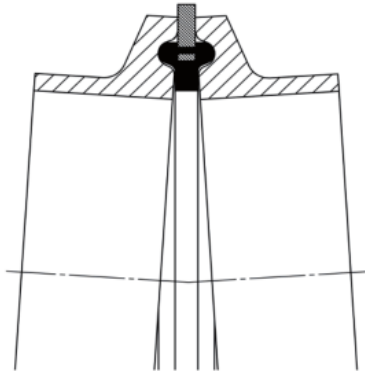
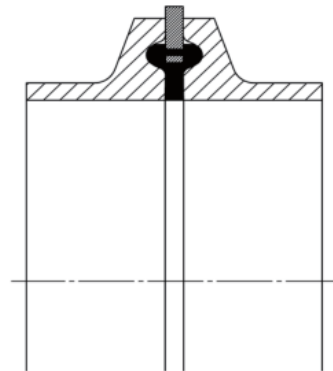

Fig. 6



- **Combining gaskets**

The Snap-On™ gasket is a more expensive product than a standard gasket. Cost is a factor in the decision process. Another nice feature of the Snap-On™ gasket is that we use the same elastomeric compound for the two products, so they can be used in the same system side by side. In connections where there is no misalignment you can use standard gaskets and in a position where there is you can instead use the Snap-On™. No need for a complete switch-over to an expensive solution.

Both gaskets are made in EPDM CMD-1004



The Snap-On™ is made of the following material:

**Ring:** ULTRAMID® (BASF) Glass-filled Nylon 66

Temperature range -20°C to 150°C

**Meets:** FDA

**Certified:** TSE/BSE (ADIF) free (EME/410/01)

**Available Elastomer Compounds:** EPDM (CMD-1004) and Platinum Silicone (CMD-1012)

**Meets:** USP Class VI-121°C (CMD-1012 also EP 3.1.9)

EC 10/2011 (EC1935/2004)

FDA 177.2600

**Certified:** TSE/BSE (ADIF) free (EME/410/01)



## AVAILABLE SIZES

---

The Snap-On™ gasket is available in ½", ¾", 1", 1.5" and 2"  
Other sizes are currently under development.



Want to know more?  
Reach us via:

 **Ultrapharma**<sup>nl</sup>

De Droogmakerij 12

1851 LX Heiloo

The Netherlands

T. +31 856 200 900

[Info@ultrapharma.com](mailto:Info@ultrapharma.com)



SANITARY GASKETS

SCREENS

ORIFICE PLATES

SAMPLING GASKETS

STEAM-FLON

TRI-BOND

STEAM-FLON REMOVABLE (EN)

STEAM-FLON REMOVABLE (D)

STEAM-FLON REMOVABLE (ES)

STEAM-FLON REMOVABLE (IT)

STEAM-FLON REMOVABLE (F)

PHARMA-CLAMP

PINCH-VALVE

DIN11864 SEALS

TORQUE-KNOB

EASY-CLAMP

ELASTO-CLAMP

STAINLESS CLAMPS

SNAP-ON

PLATINUM SILICONE

CUSTOM MADE PARTS

SPORFIX

GAUGE GUARD ISOLATOR

SLIT GASKETS

ANTI VIBRATION WING NUT